



Underground Residential Development Installation
Rules Issue Date: 12/11/2024

UNDERGROUND RESIDENTIAL DEVELOPMENT INSTALLATION RULES



411 7th Avenue
Pittsburgh, Pennsylvania 15219

Issue Date – 12/11/2024



Table of Contents

Introduction..... 3

Scope..... 3

Company Contact Information 3

Definitions..... 4

1. Project Initiation 5

2. Design Process..... 5

3. Construction Phase 5

 3.1 Customer Construction 5

 3.2 Company Construction 6

 3.3 House Energizations 7

4. Construction and Design Requirements 7

 4.1 Trenching and Conduit..... 7

 4.2 Meters 8

 4.3 Typical Company Equipment Road Profile (See Figure 9) 9

 4.4 Transformer pad for 1 phase transformer..... 9

List of Tables 10

List of Figures 12



Introduction

These rules are issued for use by Customers, builders, electrical contractors, architects, engineers, etc. regarding Underground Residential Development(s) (“URD”). The rules will be referred to hereinafter as “URD Rules.” The purpose of these URD Rules are to ensure the safe and adequate wiring and electrical equipment in URD plans.

Customers shall ensure that new buildings, structures, additions, modifications and any other construction projects keep the minimum clearances required from existing Company supply lines. These minimum clearances are specified in the National Electrical Code (“NEC”), and some local building codes. The Customer shall notify and supply construction plans to Customer Service for any project near Duquesne Light Company (“Company”) supply lines no less than twelve (12) months prior to planned construction.

These URD Rules document minimum Company requirements. Municipal and other building codes or special conditions may require additional requirements. When this occurs, the parties involved should meet with the Company to understand and reconcile all requirements, which shall be documented in writing.

Copies of these rules may be obtained at the Company offices or by writing to:

Duquesne Light Customer Service
411 Seventh Ave. (Mail Drop 6-1),
Pittsburgh, PA 15219
dlccustomerservice@duqlight.com

In addition, these URD Rules may also be accessed at www.duquesnelight.com under the **ELECTRICAL INSTALLATION RULES** selection.

Scope

These URD Rules shall apply to the installation of, or changes to, the wiring and equipment for receiving electric service in an existing or contemplated URD plan. The URD Rules do not provide every detail or every requirement on specific design requirements based on the parameters of customers, builders, electrical contractors, architects, engineers, etc.

USE OF THESE URD RULES SHALL BE AT THE USER'S OWN RISK AND EXPENSE AND USER EXPRESSLY RELEASES DUQUESNE FROM ALL LIABILITY FOR INJURY OR DAMAGE RESULTING FROM OR CAUSED BY SUCH USE INCLUDING, BUT NOT LIMITED TO, ALL PRESENT AND FUTURE DIRECT, INDIRECT, SPECIAL, PUNITIVE AND/OR CONSEQUENTIAL DAMAGES.

Company Contact Information

Customer Service (8 a.m. to 5 p.m. Monday through Friday)	412-393-7100
All Emergency Calls	412-393-7000
New Business Department	412-393-4343

Contact Duquesne Light New Business Department at 412-393-4343. Request a work order for a “New Underground Residential Development”. Provide information on location, primary point of contact (name, phone number and email) and the name of new plan (plan name can be changed in the future).

An Engineering Project Representative may need to be directly contacted for a line extension. Once the work order has been created and rough estimate of the total load is approved, contact the New Business Department or Customer Service to obtain the Engineering Project Representative’s direct contact information.



Definitions

COMPANY: Refers to the Duquesne Light Company.

CUSTOMER: Any person, partnership, association, corporation, or other legal entity lawfully receiving service from the Company; or in applicable cases, the property owner, developer, or the responsible electrical contractor acting for the Customer.

SERVICE EQUIPMENT: The necessary equipment, consisting of circuit breakers or switches with fuses, and their accessories, located near the point of entrance of the service-entrance conductors to a building area and intended to be the main control and means of cutoff for the electric supply to the premise.

COMPANY EQUIPMENT: Any conductors and apparatus required to deliver energy to the Customer's wiring system, which includes service lines, poles, pole-mounted equipment, conductors, switches, transformers, etc. including such apparatus located in or on Customer owned premises, which may include, as applicable, substations, vaults, pads, conduits, and manholes.

CUSTOMER EQUIPMENT: Any service-entrance conductors, service lateral conductors (in most cases), service equipment and all premises wiring and equipment. Customer equipment may also include the structures and enclosures located on customer premises which contain Company equipment.

INSPECTION AGENCY: An authority that Customers must have their electrical installation inspected and approved by to certify that the premises wiring, and equipment complies with the required codes and the Company's Electric Service Installation Rules.

LOAD SIDE: The side where electric power leaves a piece of service equipment and travels down the circuit to the next service equipment, device(s), or load.

METERING DEPARTMENT: The Company metering personnel assigned to the community where the service installation is requested or in progress.

READILY ACCESSIBLE: Capable of being reached quickly, for operation, inspection, replacement, without the necessity of climbing over or removing obstacles or resorting to ladders, chairs, etc.

RESIDENTIAL DEVELOPMENT: A planned project which is developed by a developer/applicant for electric service set out in a recorded plot plan of five or more adjoining unoccupied lots for the construction of single-family residences, detached or otherwise, or mobile homes and one or more five-unit apartment houses, all of which are intended for year-round occupancy, if providing electric service to such project necessitates extending the Company's existing distribution lines.

SERVICE-ENTRANCE CONDUCTORS: That portion of a Customer's service facilities supplied by the Customer between the Customer's service equipment and the service point for overhead services or the service lateral for underground services.

SERVICE LATERAL: The underground service conductors including risers, from the last Company pole, pull box, splicing chamber, transformer terminals or vault to the service-entrance conductors. When the service point is at the last Company pole, pull box, splicing chamber, transformer terminals or vault, the service lateral is owned by the customer. When the service point is at the meter in underground residential developments, the service lateral is owned by the Company.

SERVICE LINE: An electric supply line of untransformed voltage which delivers service to a residence or building as described in the Company's construction standards.

SERVICE POINT: The point of connection between Company equipment and Customer equipment. The service point usually determines the division of ownership between Company equipment and Customer equipment. The service point depends on the type of service and is defined in the Company's Tariff Rule No. 6.1.

SUPPLY LINE: The Company's overhead or underground wires or cables with the necessary poles or containing structures (ducts or conduits) and other hardware located within the public roadway or located within a utility right-of-way used for the Company's general supply system.



SUPPLY SIDE: The side from which electric power enters a piece of service equipment.

TARIFF: A set of rate schedules, rules, and regulations for providing electric service throughout the Company's service territory. The Company's Tariff is filed and approved by the Pennsylvania Public Utility Commission (PA. P.U.C.).

Unless otherwise noted, feedback from the Company's Metering Department can be received through contacting the Company's New Business Department or a Major Account Representative.

1. Project Initiation

- 1.1 Provide the Company with a PDF and AutoCAD format version of the site plan prior to municipality utility location approvals.
- 1.2 Confirm with the Engineering Project Representative that the site plan has been recorded with the appropriate entities.
- 1.3 Fill out electrical service request for each type of building and load that the URD plan will have (ex: differing home types, community centers, pumping stations, electric heating, electric vehicle chargers, etc.).
- 1.4 The developer shall receive company approved electrical layout design drawings prior to beginning trenching or equipment foundation, junctions, and pedestal/handhole site preparation.

2. Design Process

- 2.1 Coordinate with the Company's Engineering Project Representative and Design Technician to facilitate efficient design of the URD plan.
- 2.2 Let the Company know if accommodations will be needed for streetlights and for any other lighting needs (ex: monument lighting, private streetlights, municipality streetlights).
- 2.3 Note: The customer will be charged appropriately for the installation of any additional infrastructure required to feed streetlights or other lighting needs.
- 2.4 Once design is complete and sent for right of way, sign and return the documents to the Company.
- 2.5 If customer requested design changes result in additional equipment to be incorporated into the design, the customer is responsible for the cost of the additional equipment.

3. Construction Phase

Refer to the Construction and Design Requirements section for detailed requirements. This section delineates division of responsibility and inspection requirements.

- 3.1 Customer Construction
 - 3.1.1 Install the conduit facilities in the plan as specified on the designed drawings from the Company and as specified in the following document.
 - 3.1.1.1. Note: Inspections must be made by the Company Design Tech prior to backfill. No conduit should be backfilled without prior approval. Inspection requests should be made a minimum of two (2) business days in advance.
 - 3.1.1.2. All property lines must be marked with paint or flags. Lot numbers shall be similarly identified. Lots must be marked prior to installation of Company equipment.
 - 3.1.1.3. The final grade must be marked. No trenching should begin without a design and pre-approval from the Company.

- 3.1.2 Prior to requesting sectionalizing enclosure installation, an unobstructed access way capable of HS20-44 (32,000lb per axle) truck loading shall be provided and permanently maintained by the customer. The Company is to have the right of ingress and egress at all times. The Company shall be absolved from all property damages due to non-negligent ingress or egress of Company personnel or equipment.
 - 3.1.3 Notify Engineering Project Representative at least three (3) months prior to construction start date. At this time approximate schedule of street paving and anticipated energization date shall be provided.
 - 3.1.4 No trenching shall begin without the approval of the Engineering Project Representative. The developer shall notify the Company and communication companies a minimum of three (3) weeks prior to the time the developer desires to begin trenching. The Engineering Project Representative will determine the actual required date.
 - 3.1.5 All issues raised by the Design Tech must be addressed prior to moving forward with the project.
 - 3.1.6 Following Company approval at applicable steps, developer shall be responsible for trenching, backfilling, and surface restoration.
 - 3.1.7 Minimum equipment workspace clearance area dimensions shall be in accordance with Figure 12 and Table 1. Equipment dimensions for the purposes of Figure 12 and Table 1 include the ground grid. In other words, if the ground grid extends beyond the equipment enclosure in one or more directions, the dimensions given in the “Equipment Dimensions” column of Table 1 may be larger than the enclosure itself due to accounting for the ground grid.
- 3.2 Company Construction
- 3.2.1 The Customer is to provide the following quantities of material prior to the Company scheduling work. Required date and location for delivery to be coordinated between developer and Company construction supervisor. These quantities are averages per device and while some devices like secondary service enclosures require less, historical use has shown that for a new URD plan, these quantities will provide roughly the correct amount to complete the plan.
 - 3.2.1.1. 2B (ASHTO 57) Limestone: 1 cubic yard per device.
 - 3.2.1.2. Clean earth/dirt: 1 cubic yard per device.
 - 3.2.1.3. Sand: 1 cubic yard per temporary service.
 - 3.2.2 Prior to start of Company work:
 - 3.2.2.1. All gradings to be within 6” of final landscape grade, and final grade shall be specified. Area shall be free of obstructions.
 - 3.2.2.2. Provide a 9’-0” by 6’-0” clear level working area at each transformer pad, vault location, and above ground loadbreak bushing junction.
 - 3.2.2.3. At the time of installation of Company equipment, the developer shall adequately mark locations of other utilities in the area of Company construction and have the roadways adequately paved or constructed to support HS20-44 loading (32,000lb per axle).
 - 3.2.2.4. Developer to provide and install 3” schedule 40 PVC conduit for all primary and secondary cables, (See detail 7) with 1,800lb-rated 5/8” woven polyester tape for pulling cable & elbows numbered as indicated on electrical layout design drawings.
 - 3.2.2.5. Developer to provide complete trenching and backfilling as shown in figure 7. No bends permitted; only gradual field sweeps with a radius greater than 25’. If telecommunications lines are to share the same trench there is to be at least twelve (12) inches horizontal separation between DLC facilities and their facilities for the entire length of the trench.
 - 3.2.2.6. Provide and install 3” PVC schedule 40 conduits from new homes to service enclosures/transformers. See figure 6.

- 3.2.2.7. Provide and install 90°, PVC 3" schedule 80 elbows with 36" radius at transformer/switch enclosure/terminal pole locations. See figures 10 and 11 for primary and secondary. See figure 8 for Terminal Poles. Install conduit caps at all vertical 90° bends.
 - 3.2.2.8. Provide and install 3", 90°, PVC schedule 80 elbows with 24" radius at service enclosure and transformer (see Figure 11) for services.
 - 3.2.2.9. All horizontal 90° bends at road crossings to be schedule 80 with a minimum 36" radius.
- 3.3 House Energizations**
- 3.3.1 Property Owner shall call the Company's New Business department and provide street address. The New Business department will generate an internal 6-digit and external 10-digit Work Order number.
 - 3.3.2 Prior to energization being scheduled, the Company must receive the following:
 - 3.3.2.1. (1) An electrician must submit paperwork certifying that they have inspected the property's wiring and found it to comply with all applicable codes and regulations. This should be submitted to the New Business Group using the 10-digit Work Order number.
 - 3.3.2.2. (2) The meter must be installed. This will only be done once the wiring inspection is completed. This is Company work and is tracked using the internal 6-digit Work Order number.
 - 3.3.2.3. (3) Billing must be set up. Property Owner shall contact Company Customer Service to set up billing and associate it with the 10-digit Work Order number.
 - 3.3.3 Once the requirements above are met, Company will schedule the energization and notify the property owner of the date and time.

4. Construction and Design Requirements

4.1 Trenching and Conduit

- 4.1.1 If trenching within state right-of-way, conduits are to be under a minimum of 36" total coverage. If trenching within City of Pittsburgh and a permit is required, minimum coverage is 30"
- 4.1.2 The trench shall be deep enough to provide 4" of tamped select backfill below the conduit and 4" of tamped select backfill over the conduit. Above the tamped select backfill, courser earth backfill may be used, provided there are not stones over 2" in diameter. See figure 7.
- 4.1.3 Maximum length of conduit runs for primary or secondary cable not to exceed 400'. Cumulative angle of horizontal bends not to exceed 90°.
- 4.1.4 A red electrical warning tape shall be provided by the developer and shall be installed by the developer 16" directly above all conduits. This corresponds to approximately 20" below final grade for primary and secondary conduit as shown in figure 7, and 8" below final grade for service laterals as shown in figure 6.
- 4.1.5 Sectionalizing enclosures: All equipment and work shall conform to the National Electrical Safety Code and applicable Underwriters' and governmental building codes. Certain items are subject to inspection and approval by the Company.
- 4.1.6 Install at the pad, sectionalizing pit, and/or pole, 90° elbows. The elbows should be PVC schedule 80, type DB, in accordance with NEMA specification TC2. The use of PVC elbows will not require the use of grounding bushings. Extend bends 6" into pad or sectionalizing pit opening or 6" up pole. An 18"x18"x24" gravel drainage pocket shall be installed at the bottom of each conduit bend to drain conduit. Gravel used shall be 2B or ASHTO 57 limestone, free of fines, and non-compacted. ½" drainage holes shall be drilled into the underside of conduit. Holes shall be located from the end of the bend to 18" past the end of the bend, spaced on 3" centers. All

internal burrs shall be removed. The gravel drainage pocket and the conduit passing through it shall be wrapped in drainage geotextile. Install an 18 gauge pull cord with a minimum breaking strength of 1800lb in each conduit.

- 4.1.7 Conduit stubs for transformers should be oriented according to transformer pad opening as shown in Figure 10.
- 4.1.8 If telecommunications lines are to share the same trench there is to be at least twelve (12) inches horizontal separation between DLC facilities and their facilities for the entire length of the trench.
- 4.1.9 The excavation and installation of conduit shall have a final inspection by the Company prior to the backfilling of the trench. Contact the assigned Design Technician to schedule inspection with at least three (3) business days notice.

4.2 Meters

- 4.2.1 Contact the Company for meter location.
- 4.2.2 Contact PA One-Call system at 1-800-242-1776.
- 4.2.3 Furnish, install, and maintain conduit from the meter base to the Company's service enclosure or transformer at the street. See Figure 5.
 - 4.2.3.1. At the meter base, install a riser conduit and secure to the structure. The company recommends that the customer use a Slip joint connection. See Figure 13.. Install a 3" diameter, 24" radius bend. An 18"x18"x18" gravel drainage pocket shall be installed at the bottom of each conduit bend to drain conduit. Gravel used shall be 2B or ASHTO 57 limestone, free of fines, and non-compacted. Drill four 1/2" diameter holes, spaced on 3" centers, starting from the low point of the bend and proceeding away from the bend. All internal burrs shall be removed. The gravel drainage pocket and the conduit passing through it shall be wrapped in drainage geotextile. Riser conduit and 24" radius bend shall be 3" nominal PVC, schedule 80 per NEMA TC2 (EPC-80-PVC for type IV applications), gray in color only. (All conduit with less than 18" of cover must be schedule 80.) Extend 3" diameter conduit from the meter base to Company's service enclosure or transformer at the street. Service lateral conduit and bend must be 3" nominal PVC, Schedule 40 per NEMA TC2 (EPC-40-PVC for type II applications), gray in color only. Take proper care to prevent debris from entering conduit. Install a 1/4" nylon or polypropylene pulling line within the conduit. Be sure line moves freely after solvent cement has cured. Trench must be deep enough to provide 4" of tamped select backfill below the conduit and 3" of tamped select backfill over the conduit. The minimum total cover over the conduit is to be 24", see figure 6. Select backfill shall consist of sand, crushed stone (such as limestone fragments/dust) or other material approved by the Company. Remaining backfill shall be free of materials that may damage the conduit, and must not contain solid material (rocks, stones, etc.) larger than 2" or with sharp edges.
 - 4.2.3.2. If a transformer or service enclosure is being installed in expectation of future services being run to presently empty lots, conduit must be installed from the transformer or service enclosure in the direction of each expected future meter base. Conduit must extend at least 18" beyond a service enclosure or 30" beyond a transformer. These measurements are taken from what will be the edge of the enclosure or pad at grade level. Conduit ends are to be capped to prevent dirt ingress. Location of Conduit ends are to be marked either by placing a straight section of conduit vertically (as shown in Figure 5) at the end of the conduit, or in lieu of capping underground, attaching a Sch. 80 bend extending above grade and capping that. If a bend is used to mark the conduit, it may be re-used later as the meter base riser.
 - 4.2.3.3. Service lateral conduit to extend directly in a straight line from the meter base to the Company's service enclosure or transformer at the street without any bends or sweeps. If

additional bends or sweeps are anticipated, or if the length of the service exceeds 100', the customer must submit a drawing of the proposed conduit path to the company for approval before installing the conduit.

- 4.2.3.4. A 2 ½" nominal riser conduit may be used if the meter base has no 3" knockout. The riser must be PVC schedule 80 per NEMA TC2 (EPC-80-PVC for type IV applications) and installed and secured as above. Connect the riser to the schedule 80 bend with a reducer fitting meeting NEMA TC3.
- 4.2.4 For service laterals exceeding 100', the customer should contact WESCO @ 412-393-8241 to purchase an auxiliary service enclosure, meeting Company stock number 240339 specs.
- 4.2.5 The Company will furnish, install, connect, and maintain the service lateral cable up to a maximum of 100'.

4.3 Typical Company Equipment Road Profile (See Figure 9)

- 4.3.1 When no sidewalks are planned, Company equipment shall be located no closer than 5' from the curb-line and within the road right-of-way.
- 4.3.2 If sidewalks are planned, Company equipment is to be located no further than 13'-6" from the curb-line to the face of equipment, which may require Company facilities within the 10' utility easement.
- 4.3.3 All trenches are to maintain the same distance from the face of Company equipment throughout the development, and to be as straight as possible. The centerline of trenches for Company cables shall be no further than 2' from the face of equipment.
- 4.3.4 Distances may vary according to municipality requirements.
- 4.3.5 Maintain a minimum of 3' horizontal separation from other utilities not in the same trench, such as gas and sewage, unless municipal ordinance stipulates otherwise. Company equipment (transformers and sectionalizing enclosures, along with their respective ground grids) shall be a minimum of 5' from all other utilities.
- 4.3.6 The Company's primary electric facilities shall be on the opposite side of the street from water lines. Any deviations from this requirement must be reviewed and approved by Company engineering.
- 4.3.7 Company facilities shall not be located under sidewalks, preferred design is 2 foot minimum behind any sidewalk.
- 4.3.8 No Trees, shrubs, etc. shall be planted within 6' of edges of trenches for Company cables.

4.4 Transformer pad for 1 phase transformer

- 4.4.1 Tamp earth fill and limestone to prevent settling.
- 4.4.2 For exact location of transformer pad, see construction drawings. In general, locate pad 1'-0" minimum from front property line. Pad should be located 5'-0" minimum from curb-line. A minimum 9'x6' clear working space must be maintained in front of the transformer. The Company must have a minimum of 5' of clearance around all equipment. See Figure 12 and Table 1.
- 4.4.3 If streetlights are required, the developer shall install a 2" schedule 80 36" radius elbow and extend conduit to within 2' of the street light . Conduit ends should be capped and marked visibly to show then end of the conduit run.











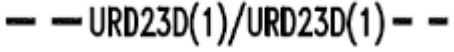
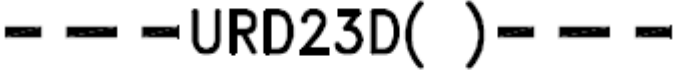

List of Tables

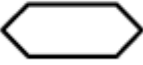
Table I
WORKSPACE CLEARANCE AREAS
(SEE FIGURE 12)

Equipment	Equipment Dimensions	Equipment Clearance from Company Equipment Centerline (FT)			Front
		A	B	C	D
Transformer	6' x 6'	6'	6'	6'	9' x 6'
Fiberglass Loadbreak Bushing Junction	10'L x 7' - 6"W	11'	8'	11'	9' x 6'
Fiberglass Vault	3' x 3'	3' - 6"	3' - 6"	3' - 6"	9' x 6'
Secondary Enclosure	2'L x 1'W	2'	1' - 6"	2'	3' x 6'

Table II
MAP SYMBOL LEGEND

Symbol	Meaning
	Replace 2/C #2 23kV Al Cable in 3" PVC Conduit
	Install 2/C #2, 23KV Al. Cable. Number of phases to be indicated on construction drawing.
	Install 3/C 600V Cable
	Install Underground Residential Service Cables
	Existing road crossing
	Above ground loadbreak bushing junction
	Install LED luminaire
	Future street light location
	Install UG service enclosure (round)
	Install UG service enclosure (rectangular)
	Install transformer pad
	Install URD vault (Pull box)

List of Figures

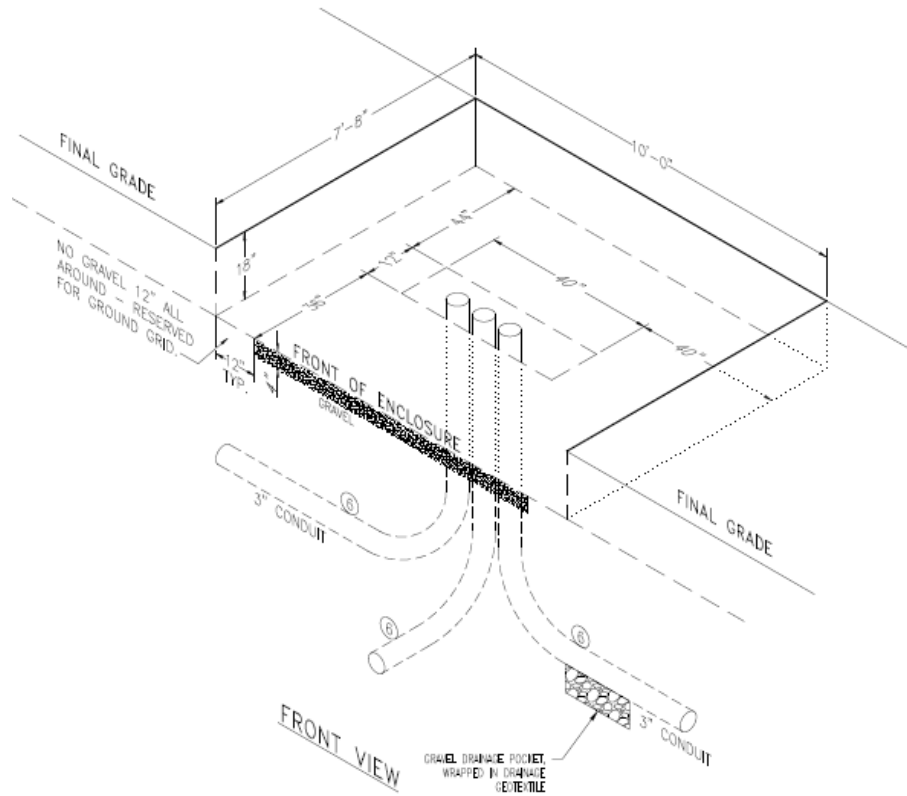
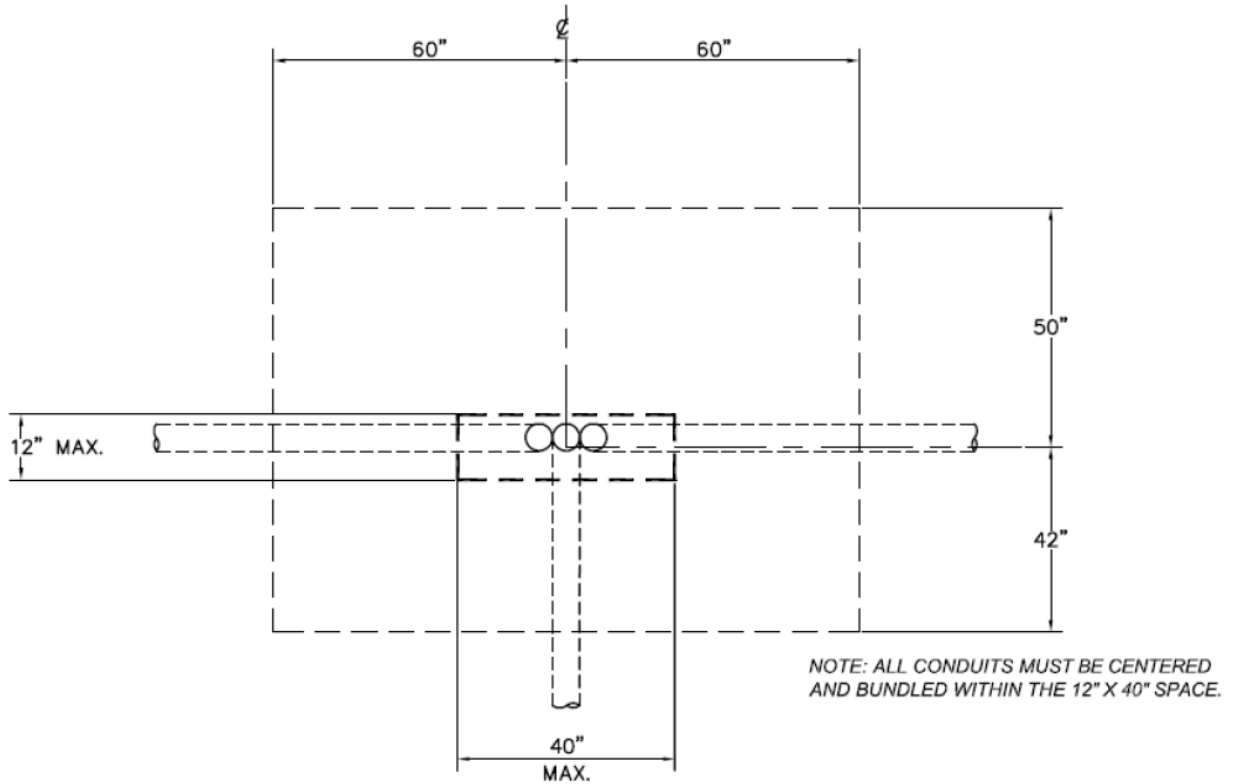

FIGURE 1.
EXCAVATION WORK FOR 3-PHASE
FIBERGLASS SECTIONALIZING ENCLOSURE



FRONT OF ENCLOSURE

FIGURE 2.
TYPICAL CONDUIT AND SWEEP PLACEMENT
AREA FOR SECTIONALIZING ENCLOSURE
(8 BENDS MAX)

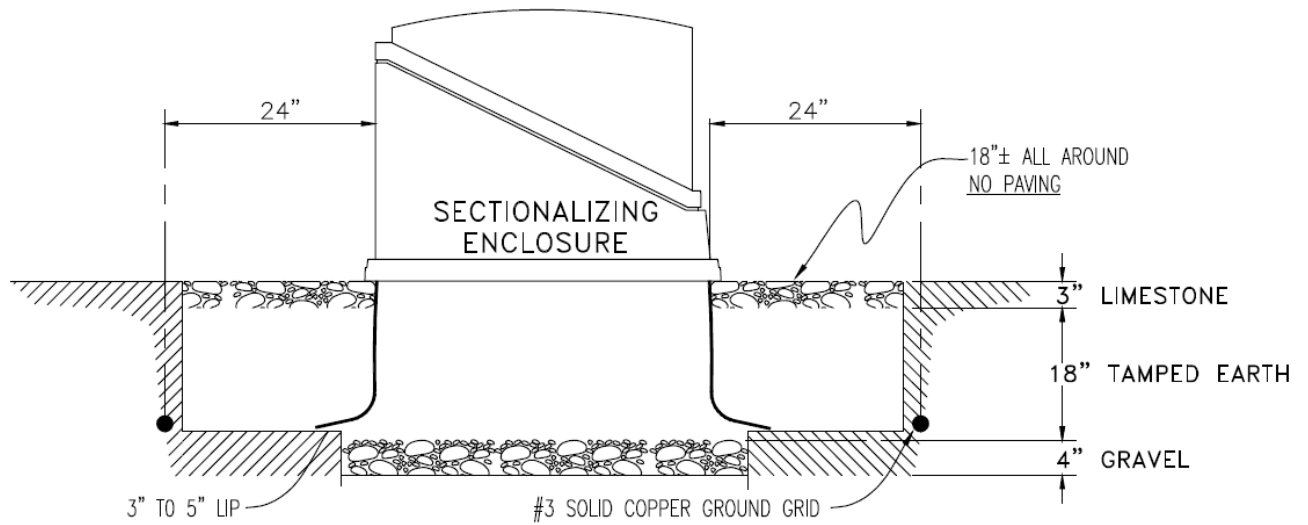

FIGURE 3.
(SIDE VIEW)
SECTIONALIZING ENCLOSURE PROFILE

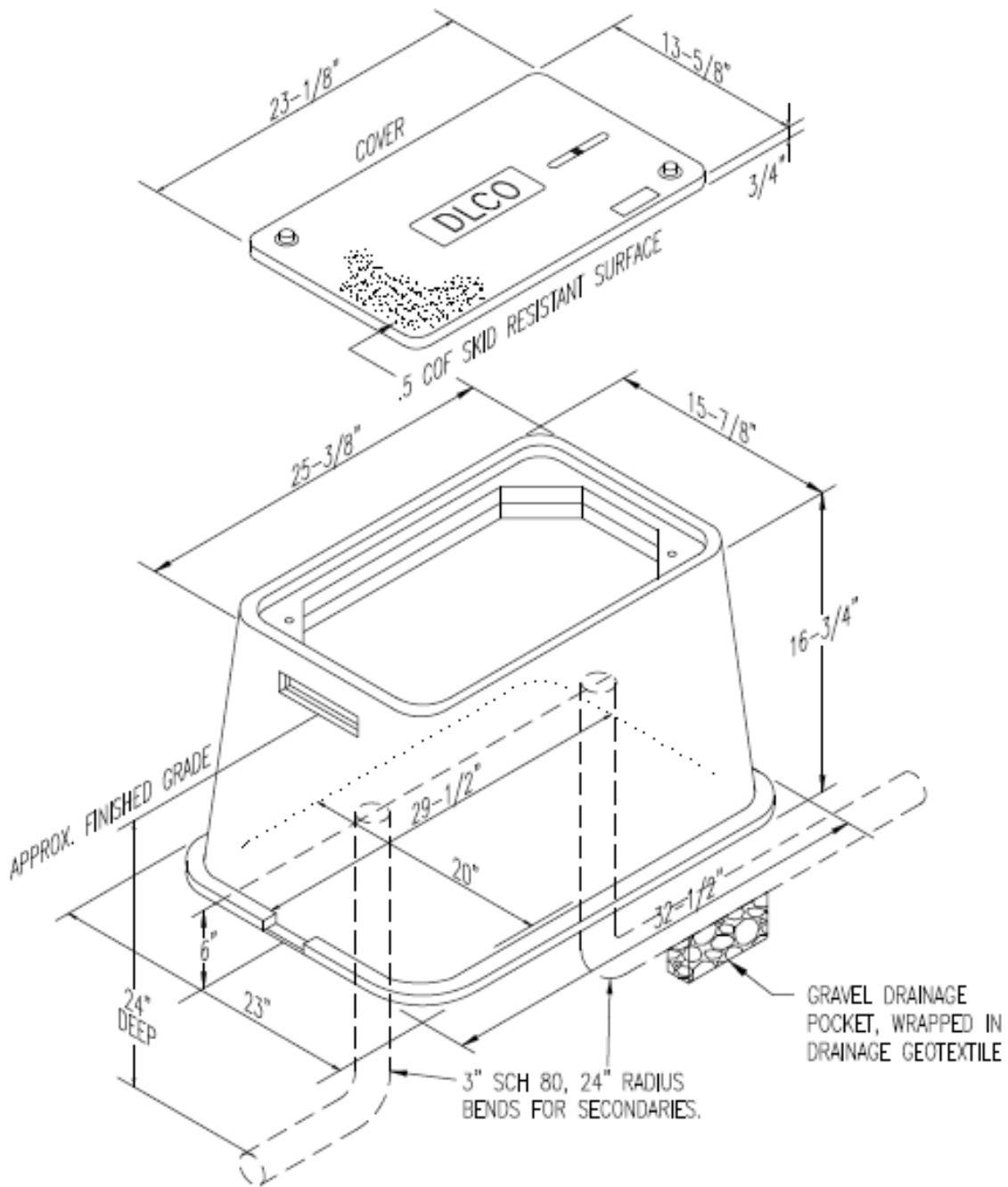

FIGURE 4.
SERVICE ENCLOSURE

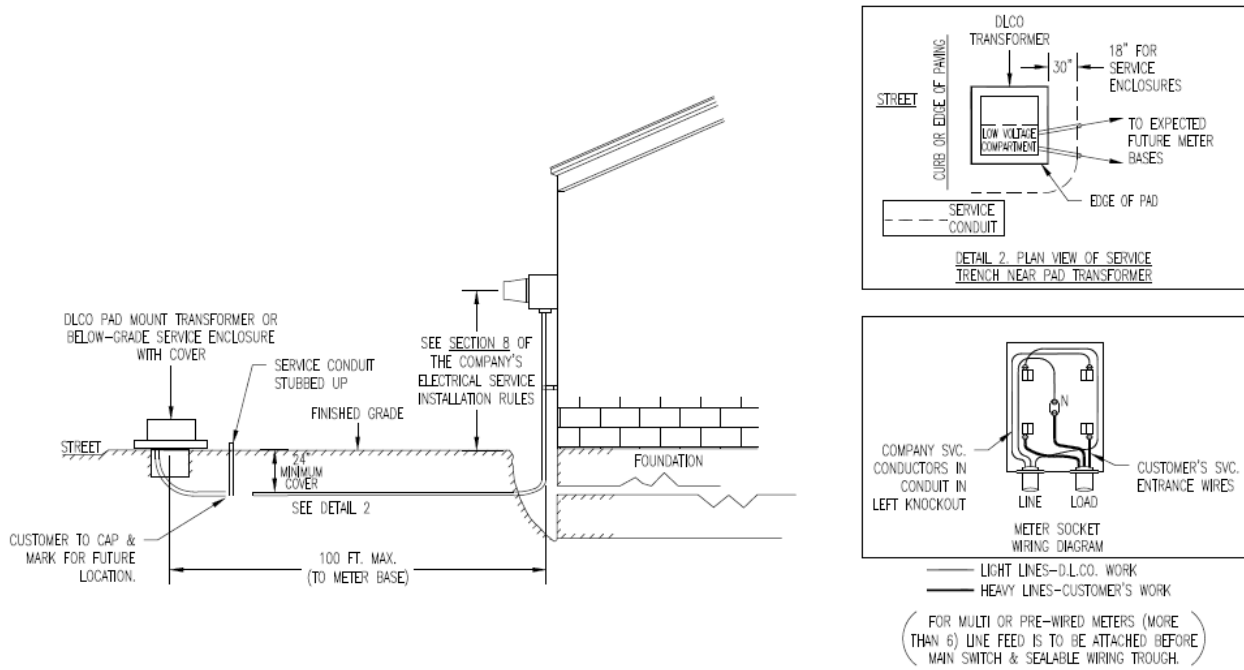

FIGURE 5.
 URD SERVICE LATERAL AND METER

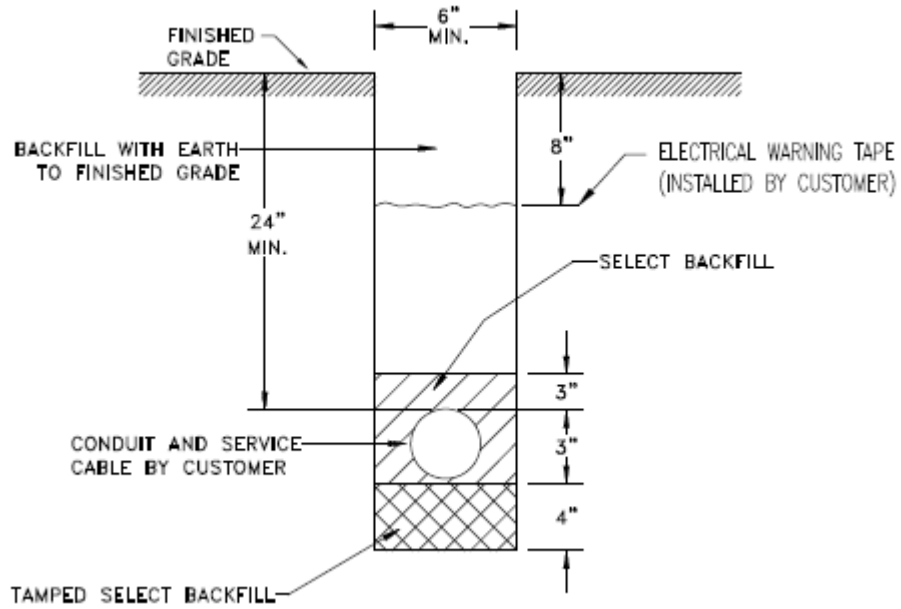

FIGURE 6.
SECONDARY SERVICE CONDUIT
TRENCH DETAIL

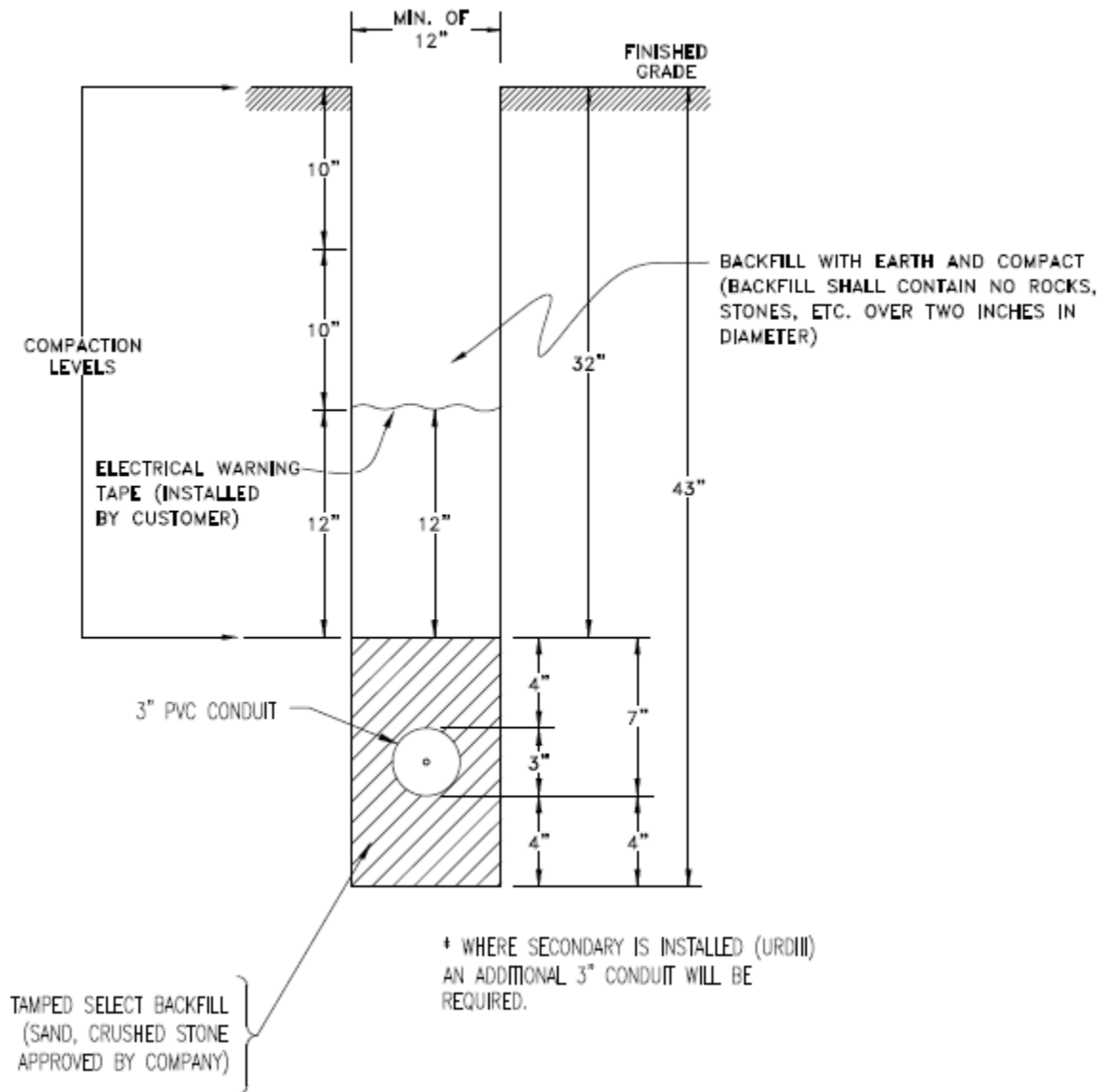

FIGURE 7A.
PRIMARY DISTRIBUTION CONDUIT
TRENCH DETAIL

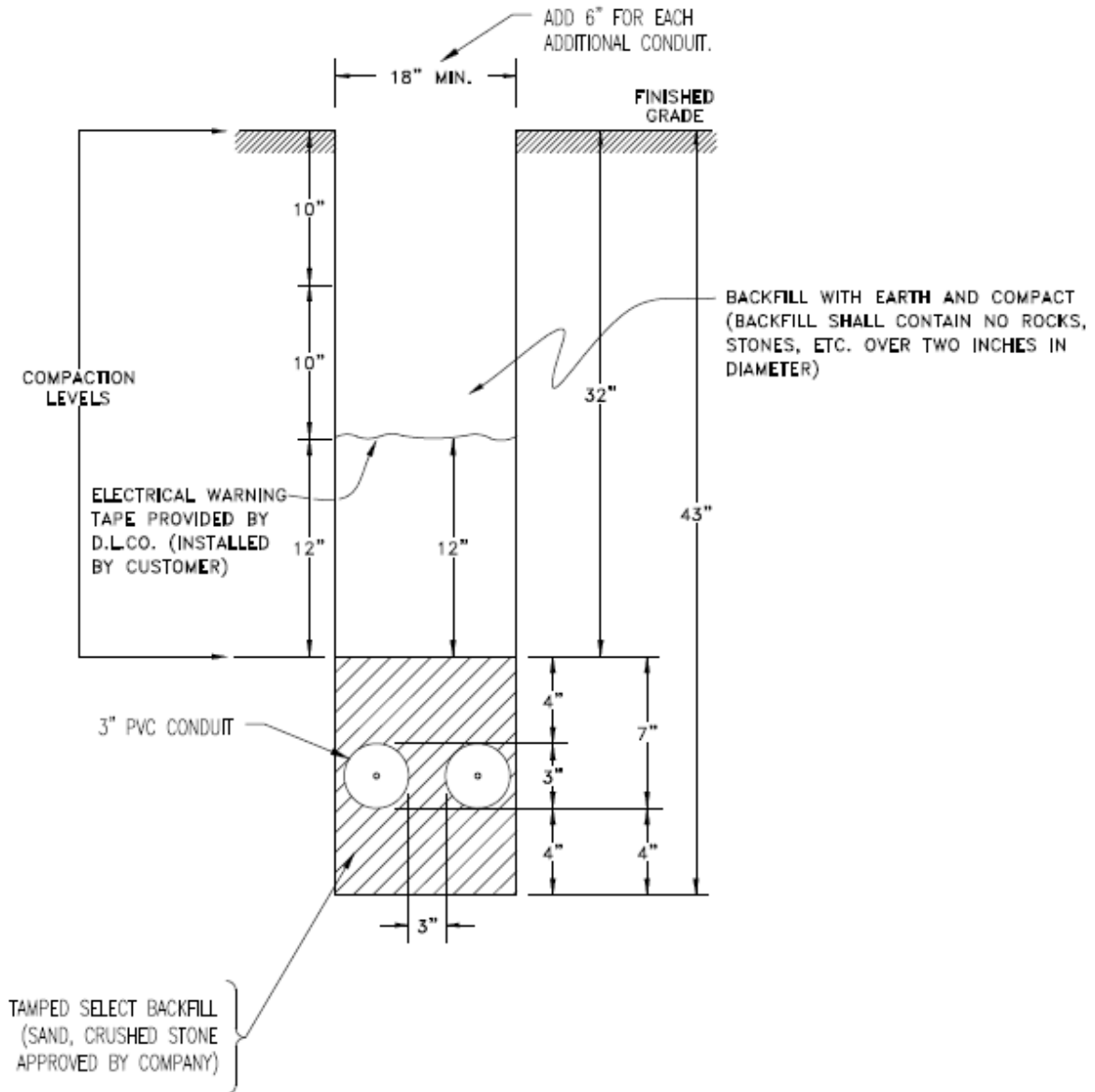

FIGURE 7B.
 PRIMARY DISTRIBUTION CONDUIT
 TRENCH DETAIL
 (MULTIPLE CONDUITS)

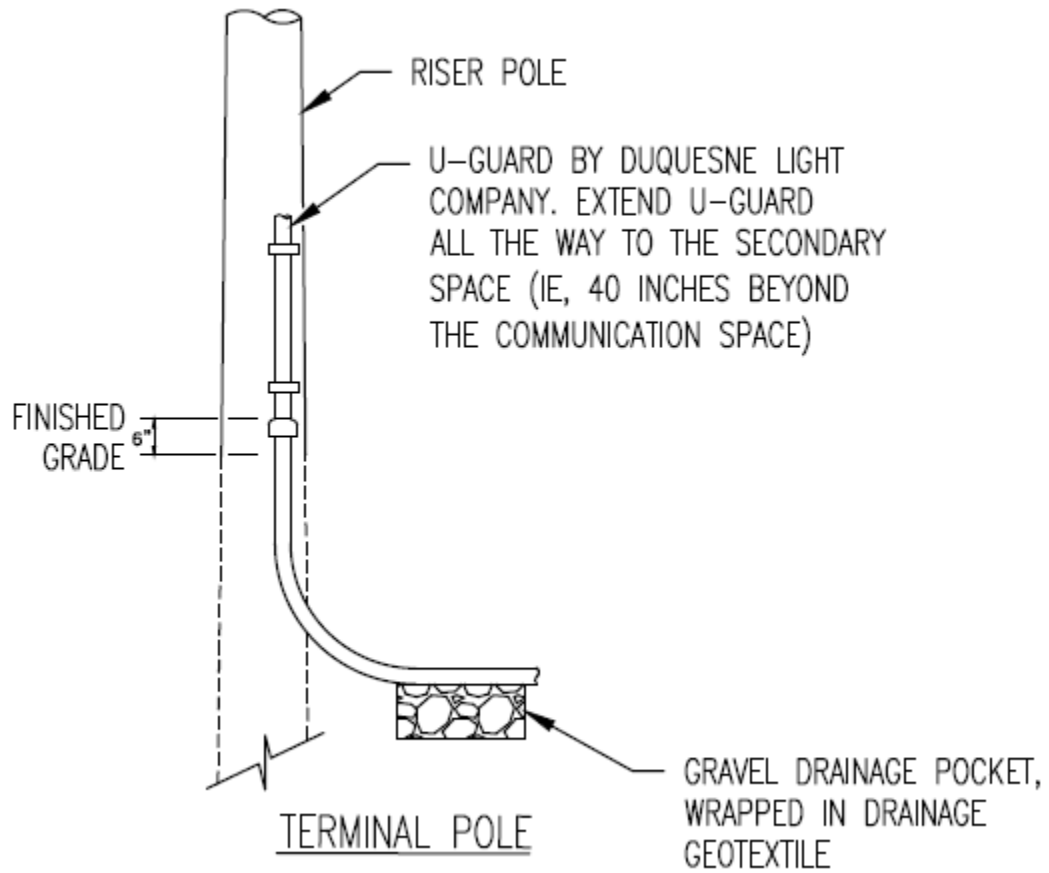

FIGURE 8.
TERMINAL POLE

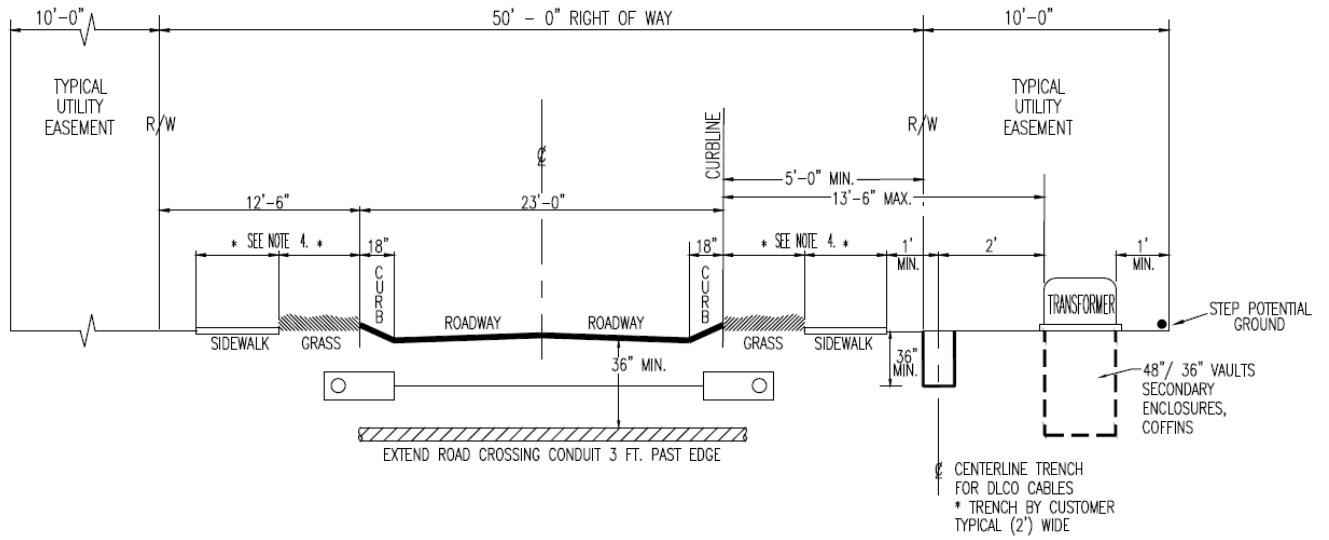

FIGURE 9.
TYPICAL ROAD PROFILE

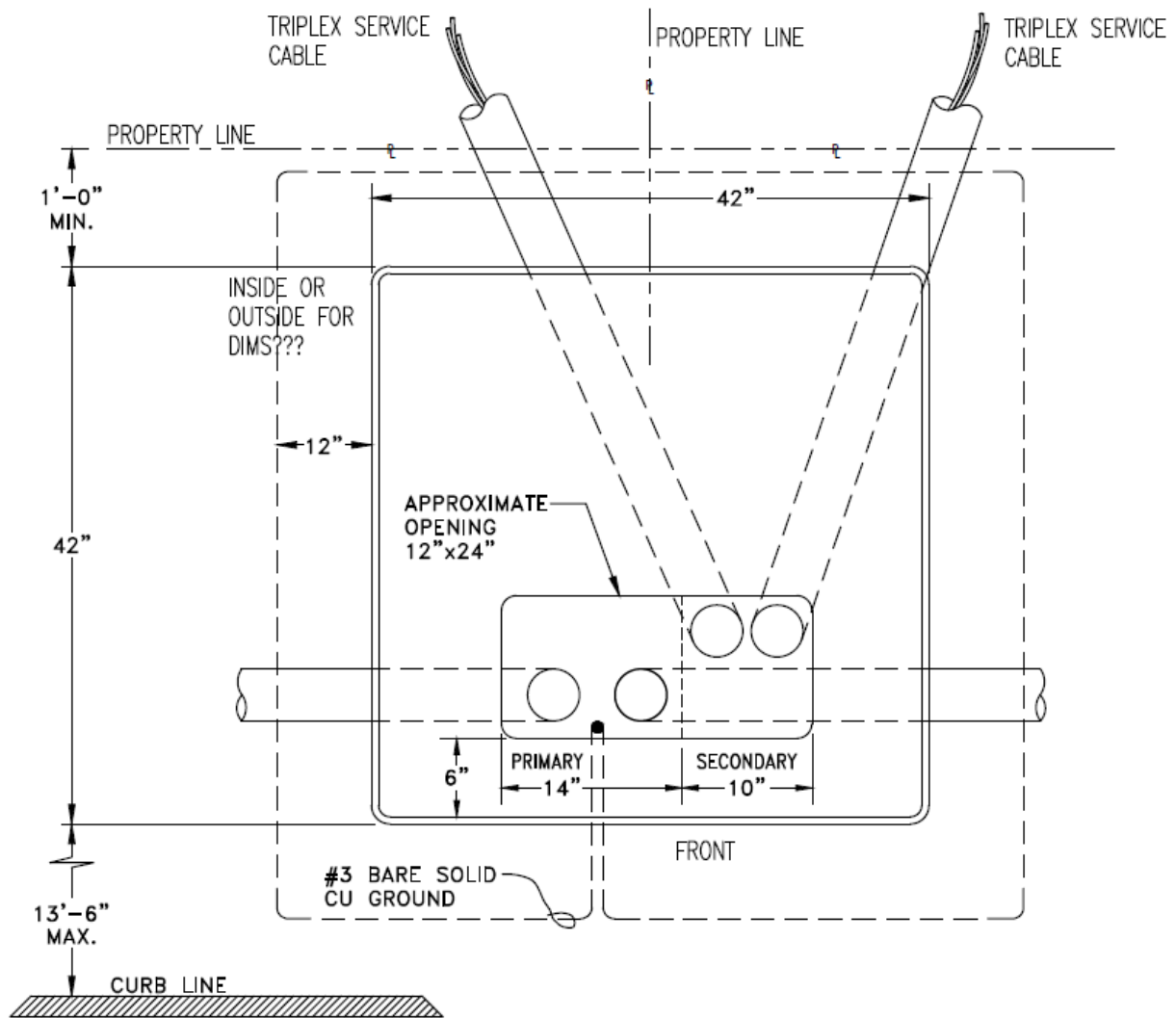

FIGURE 10.
1-PHASE TRANSFORMER PAD DETAILS
(TOP VIEW)

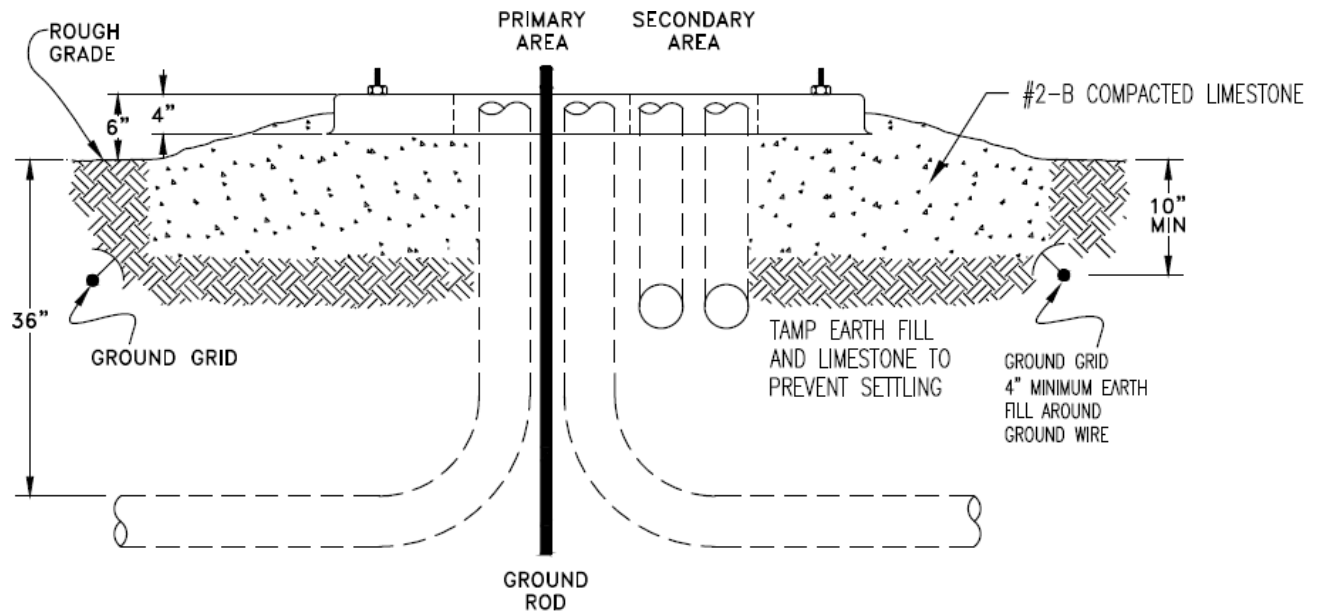

FIGURE 11.
1-PHASE TRANSFORMER PAD DETAILS
(SIDE VIEW)

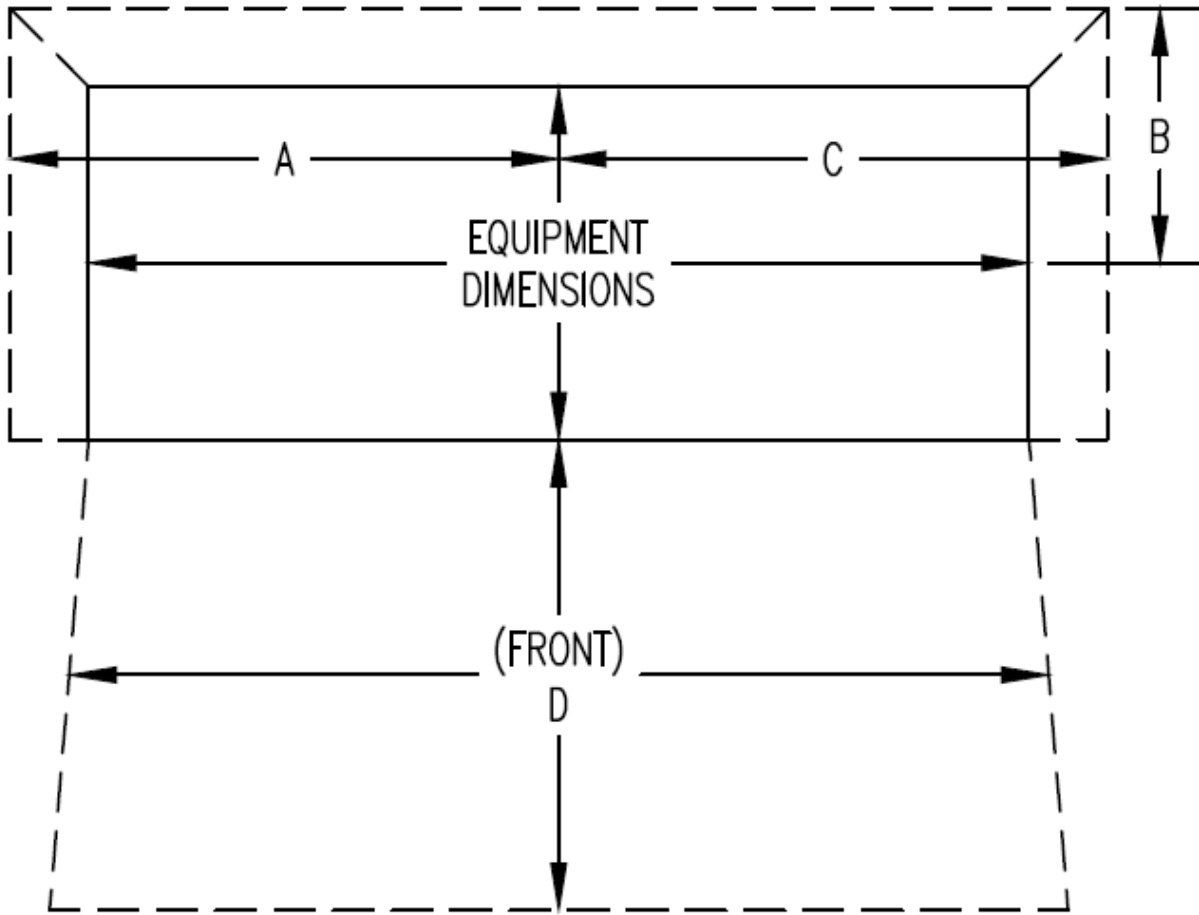
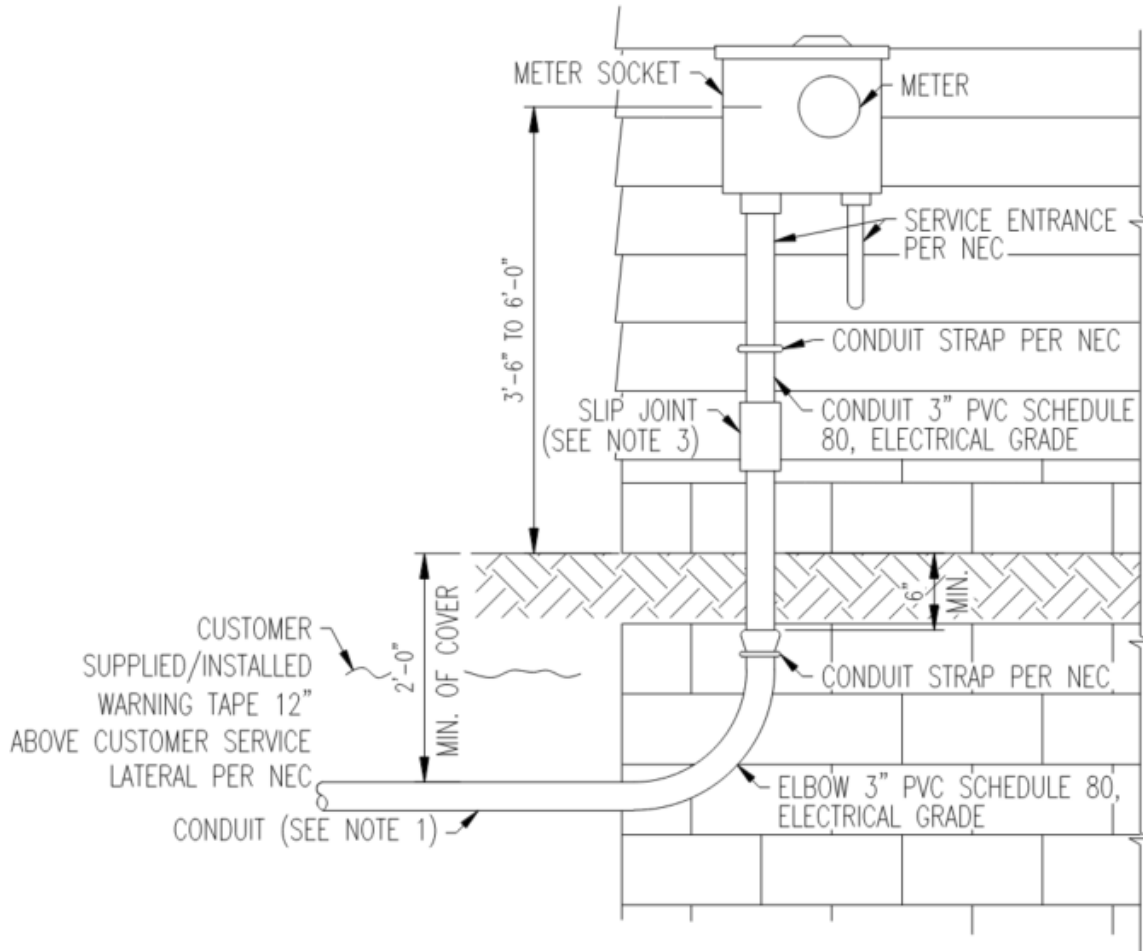

FIGURE 12.
WORKSPACE CLEARANCE AREAS



NOTES

1. THE CUSTOMER SHALL PROVIDE A TRENCH THAT IS WELL TAMPED AND FIRM.
2. WHEN THE CUSTOMER IS REQUIRED TO INSTALL CABLE, PROVIDE AMPLE CABLE SLACK TO ALLOW FOR CABLE MOVEMENT. THE COMPANY RECOMMENDS LEAVING LOOPS IN THE METER SOCKET.
3. THE CUSTOMER SHALL PROVIDE GROUND MOVEMENT PROTECTION PER 2023 NEC 300.5(J) TO PREVENT DAMAGE DUE TO SETTLEMENT OR MOVEMENT, INCLUDING FROST HEAVE. THE COMPANY RECOMMENDS THAT THE CUSTOMER USE A SLIP-JOINT CONDUIT PRODUCT. ANY SLIP-JOINT DESIGN THAT MEETS THE AFOREMENTIONED NEC CODE AND MADE OF SCHEDULE 80 PVC IS ACCEPTABLE.
4. CUSTOMER SHALL PROVIDE CONDUIT STRAP ON EITHER ENDS OF THE GROUND MOVEMENT PROTECTION (SLIP-JOINT) PER NEC OR DLC WILL NOT ENERGIZE OR PERFORM WORK.

FIGURE 13.
 TYPICAL UNDERGROUND SERVICE LATERAL
 EXPANSION FITTING INSTALLATION